

# SENIOR FLEXONICS RUBBER EXPANSION JOINTS

Senior Flexonics stocks and distributes a comprehensive range of rubber expansion joints for use in many tough, demanding industrial applications such as air conditioning, heating and ventilation systems, petrochemical, industrial process piping systems, power generation, marine services, paper, water and sewerage systems.

Senior Flexonics standard rubber expansion joints feature an engineered sphere design bellows which is inherently stronger than the hand fabricated old standard cylindrical shapes. Internal pressure within a sphere is exerted in all directions distributing forces evenly over a large area.

The spherical design “flowing arch” reduces turbulence, sediment build-up, thrust area and the effects of thrust on the piping system equipment when compared to the “high arch” design.

Standard stock units in styles 101 and 102 are constructed from EPDM rubber inner liner and outer cover, with an embedded nylon cord reinforcement and wire reinforced flanged collars. Floating flanges allow for easy installation and alignment of bolt holes.

Other materials and styles of rubber flexible joints are available on request or can be designed to meet customers' specific requirements.

## DESIGN DATA :

### STYLE 101 SINGLE SPHERE CONNECTORS

### STYLE 102 TWIN SPHERE CONNECTORS

Size (in)	Style	F/F	Allowable Movements				Pressure @ 70° F psig
			Compression	Extension	Lateral	Angular	
1 1/2	RJ-101-EP-024	6	1/2	3/8	1/2	15°	214
	RJ-102-EP-024	7	2	1 3/16	1 3/4	35°	
2	RJ-101-EP-032	6	1/2	3/8	1/2	15°	214
	RJ-102-EP-032	7	2	1 3/16	1 3/4	35°	
2 1/2	RJ-101-EP-040	6	1/2	3/8	1/2	15°	214
	RJ-102-EP-040	7	2	1 3/16	1 3/4	35°	
3	RJ-101-EP-048	6	1/2	3/8	1/2	15°	214
	RJ-102-EP-048	7	2	1 3/8	1 3/4	35°	
4	RJ-101-EP-064	6	5/8	3/8	1/2	15°	214
	RJ-102-EP-064	9	2	1 3/8	1 1/2	35°	
5	RJ-101-EP-080	6	5/8	3/8	1/2	15°	214
	RJ-102-EP-080	9	2	1 3/8	1 1/2	35°	
6	RJ-101-EP-096	6	5/8	3/8	1/2	15°	214
	RJ-102-EP-096	9	2	1 3/8	1 1/2	35°	
8	RJ-101-EP-128	6	5/8	3/8	1/2	15°	214
	RJ-102-EP-128	13	2 1/4	1 3/8	1 3/8	35°	
10	RJ-101-EP-160	8	5/8	1/2	3/4	15°	214
	RJ-102-EP-160	13	2 1/4	1 3/8	1 3/8	35°	
12	RJ-101-EP-192	8	3/4	1/2	3/4	15°	214
	RJ-102-EP-192	13	2 1/4	1 3/8	1 3/8	35°	
14	RJ-101-EP-224	8	3/4	1/2	3/4	15°	114
16	RJ-101-EP-256	8	3/4	1/2	3/4	15°	114
18	RJ-101-EP-288	8	3/4	1/2	3/4	15°	114
20	RJ-101-EP-320	8	3/4	1/2	3/4	15°	114

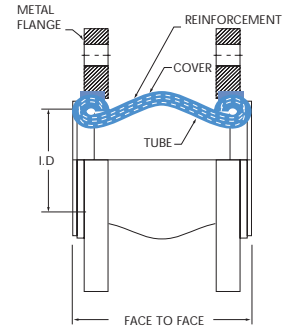

STYLE 101

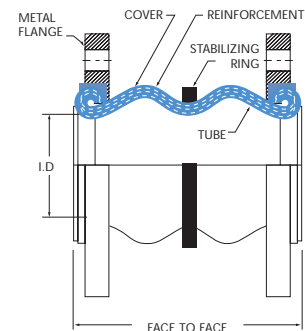

STYLE 102

### Pressure Temperature Correction Factors

100°F	X 1.0
140°F	X 0.85
170°F	X 0.65
200°F	X 0.35

Movements given are non-concurrent. Consult Senior Flexonics for concurrent movement capabilities. Pressure rating is based on 70°F operating temperature. Maximum operating temp. 212°F. At higher temperatures the pressure rating must be reduced as per chart. Other sizes, styles and materials available upon request.

# SENIOR FLEXONICS RUBBER EXPANSION JOINTS

## FEATURES :

- Precision molded design eliminates transmission of noise and vibration, cushions water hammer and smooths out pumping impulses and waterborne noises.
- Excellent for suction and discharge installations. The inherent design strength of the spherical arch allows for high operating pressure ( up to 214 PSIG). The nylon reinforcement permits the use of SERIES 100 rubber expansion joints under vacuum conditions (up to 25 in. of Hg).
- Easy installation on piping due to the elastic spherical body.

## Applications:

- Pulp and Paper
- Petrochemical
- Shipbuilding
- Pumps
- Circulating Water Lines
- Chemical
- Power Plants
- Waste Water Treatment
- Steel and Mining
- HVAC
- Compressors
- Turbine to Condensor
- Refrigeration
- Sewage

## CONTROL UNITS

Control Rod/Unit Applications. Control Units are designed to absorb static pressure thrust developed at the expansion joint. When used in this manner, control unit assemblies are an additional safety feature, minimizing possible failure of the expansion joint or damage to the equipment.

1. **Anchored Systems:** Control unit assemblies are not required in piping systems that are anchored on both sides of the expansion joint, provided piping movements are within the rated movements as shown in the Design Data on page 26.
2. **Unanchored Systems:** Control unit assemblies are always recommended in unanchored systems. Additionally, control unit assemblies must be used when the maximum pressure exceeds the limit shown in the table below, or the movement exceeds the rated movement as shown in the Design Data on page 26.
3. **Spring Mounted Equipment:** Control unit assemblies are always recommended for spring mounted equipment. Control units must be used when the maximum pressure is higher than the ratings shown in the table below, or the movement exceeds the rated movement as shown in the Design Data on page 26.

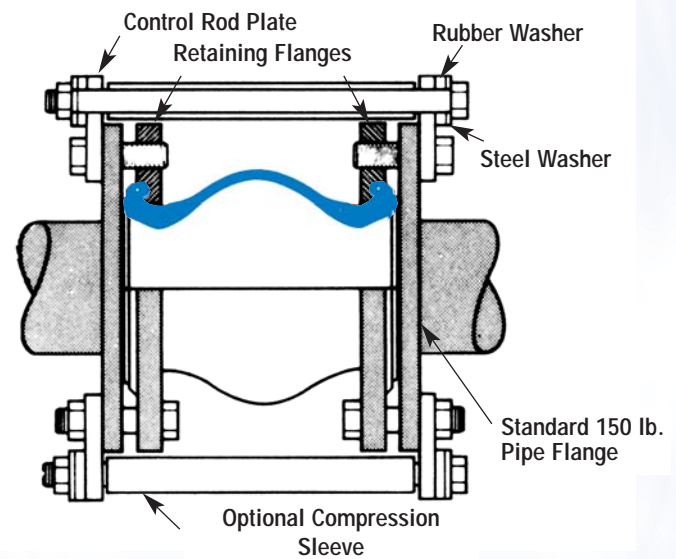

Typical example of a tie rod arrangement.

Depending upon size/pressure, two or more rods will be required.

Control Rod Unit must be installed when pressure (test, surge, operating) exceeds the rating below.

SIZE (in)	STYLE 101 (PSIG)	STYLE 102 (PSIG)
1-4	150	150
5-10	135	135
12-14	90	90
16-24	45	45